

DESIGN CONSIDERATIONS

The patented RailEasy™ Cable Railing System is designed to be used with existing or new wood (or in some cases, metal) posts. Make sure that all post material and attachments (rails) are constructed of approved materials per your local building code. Most building departments have a simple set of deck building criteria that are easy to follow. For commercial projects, the requirements may be different and the building department should be consulted.

For cable sections using the RailEasy™ Swivel End, there must be a tensioner on one end and the total cable span may not exceed 25 feet (mid post required as specified).

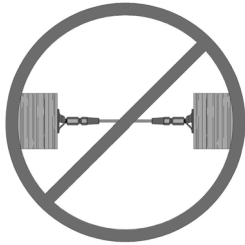

For cable sections using the RailEasy™ Cable Sleeve to accommodate a corner, the specifications are as follows (mid post required as specified).

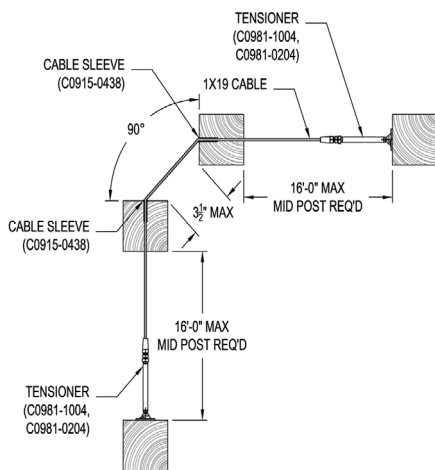

Follow the recommended tensioning sequence below to ensure proper installation and to achieve optimal results.

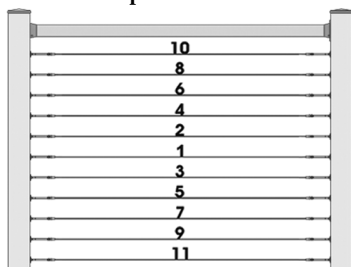

CODE COMPLIANCY

Questions are often raised regarding horizontal railings and their use in residential applications. In 2001, the ICC removed the "ladder effect" restriction on horizontal railings and the questions of safety were revisited in a three year study, concluded in 2008. The ICC concluded that the most current documentation shows no indication that a problem exists with climbable guard rails and that there has not been sufficient justification established to mandate a higher level of climbability restriction on guard rails than what is currently required in the 2006 ICC codes. In summary, the current ICC developed codes (the International Building Codes) does not prohibit climbable or horizontal railings.

ALWAYS CONSULT YOUR LOCAL BUILDING CODE

POST CONSTRUCTION & CONFIGURATION

End Posts and Corner Posts

A key factor in any successful deck rail application is always the attachment of the post to the decking. Municipal building departments usually provide specific drawings and examples of preferred post attachment methods. Substantial end and corner posts are always necessary to prevent the posts from bending under the cable tension. If post material is not strong enough to withstand tension, it may cause the post to bow and the cables to sag. A minimum 4x4 (3-1/2" square) post is required. Cable components are required on each end of a cable run.

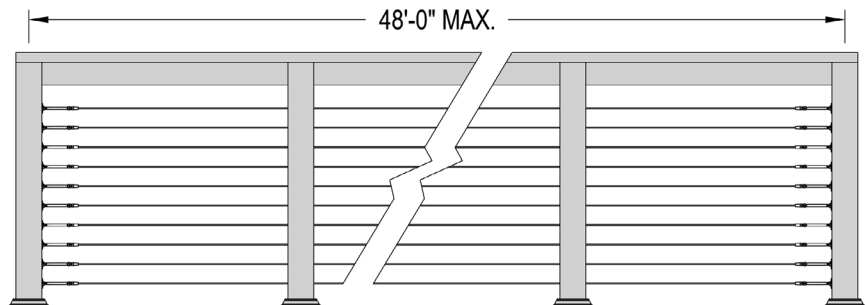

For straight cable sections using the RailEasy™ Tensioner at each end, you may run cable up to 48 feet in total length (mid post required as specified).

Mid Posts

Mid posts should be placed at intervals between end or corner posts as frequently as necessary to meet building code requirements. We recommend intermediate posts be placed every 4 feet to maintain cable spans with minimum deflection. Never exceed a spacing of 60" between posts. For each foot over 4 feet that you run cable, you must move your cable 1/4" closer together. For example, the cable spacing would be 2-3/4" for a cable span of 5 feet. If you wish to maintain 3" spacing for cable sections that span over 5 feet, we offer a Cable Stabilizer Kit made from 1" stainless steel tubing. The stabilizer bar is mounted with simple brackets and will minimize cable deflection.

Rails

A top rail is always necessary when building a wood railing with cable railing infill. The top rail should always be installed to absorb and deflect the pressure applied when cable is tensioned. It is highly recommended to secure the top rails between the post rather than simply placing the rail on top of the posts. The addition of bottom rails will provide more support to any railing system and they allow for a foot rest when leaning on the railing.

GETTING STARTED

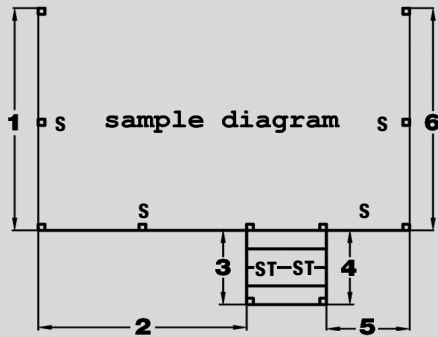

Sketch your project

Sketch your project to aid in the process of ordering your cable railing system. Indicate the location of the rails and the posts on the deck and any stairs. Number each cable section on your project sketch. **Note:** A “cable section” is the total length between end posts and corner posts, as well as, the total length between top and bottom stair posts.

ALWAYS CONSULT YOUR LOCAL BUILDING CODE

STEP-BY-STEP ORDERING

STEP 1 - Determine the type of cable section

A “cable section” is the total length between end posts and corner posts, as well as, the total length between top and bottom stair posts (refer to sample diagram). Using this key, label the sections accordingly in the “Step 1” column of the chart below.

- S** = Straight
- C** = Greater than 45 degree angle
- CA** = Less than 45 degree angle
- ST** = Stairway

STEP 2 - Measure your cable sections

Record each cable section length in the “Step 2” column of the Easy Ordering Chart below. **Maximum length for a section is 48 FEET. Sections over 48 FEET must be split.**

STEP 3 - Determine the number of cable rows and components needed

Measure the distance from the top of your bottom rail or deck to the bottom of your top rail in inches. Divide that measurement by 3, round down to the nearest whole number and subtract 1.

Example: A 36” high railing with 34” between deck and bottom of top rail.
34 divided by 3=11.33, round to 11-1=10 rows

STEP 3 - Continued

Record railing height and the number of rows in the first two fields on the Easy Ordering Chart. Based on the notation below, determine which components are fit for your job and record them in “Step 3” of the chart. **Note:** Straight sections over 25 feet require RailEasy™ Tensioners at both ends. Straight sections less than 25 feet may use a RailEasy™ Swivel fitting at one end. Stairway railings should use a RailEasy™ Swivel fitting or RailEasy™ Cable Sleeve at top post.

SELECTING CABLE COMPONENTS

Tensioner - Straight sections greater than 25 feet require tensioners at both ends. Straight sections less than 25 feet use a tensioner at one end with a swivel end at the other.

Swivel - Swivel end is designed for use in short runs and straight sections less than 25 feet with a tensioner at the other end. Do not use swivel ends at each end of a cable section.

Cable Sleeve - Stainless cable sleeves are used to accommodate cable sections with mid posts angled less than 90 degrees. Stair railing may use a sleeve at the top post when there is a straight transition from a straight section into a stair section.

EASY ORDERING CHART

Railing Height			# of Rows			
	STEP 1	STEP 2	STEP 3 Components			NOTES:
Cable Sections	Type	Cable Length	Tensioner	Swivel	Cable Sleeve	
Cable Section 1						
Cable Section 2						
Cable Section 3						
Cable Section 4						
Cable Section 5						
Cable Section 6						
Cable Section 7						
Cable Section 8						
Cable Section 9						
Cable Section 10						
Cable Section 11						
Cable Section 12						
Totals						
Total Cable Length x # of Rows						
Hardware Components		Individual				
		10 Packs				
Cable Rolls		500 Feet				
		100 Feet				